



AirIDEA

powietrze nigdy nie było tak eleganckie



CIRCLE



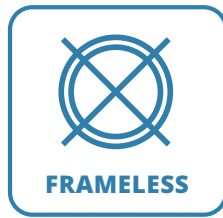

The round slot CIRCLE diffuser fits perfectly in rooms of a variety of sizes. It can be used for both air supply and air extraction. It is possible to use several units in one room. Various connection sleeves are available. The cap is attached with magnets.

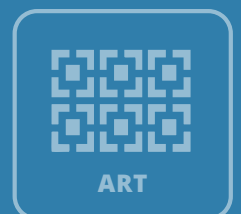
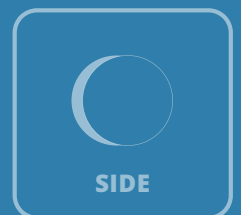
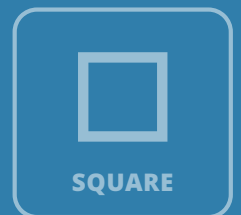
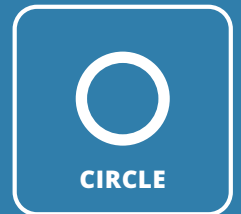
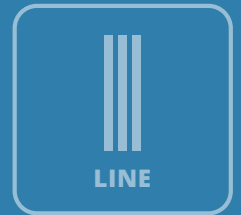

Installation
Video instructions:
 YouTube

CIRCLE 100/125

ROUND DIFFUSER



100/125 mm
DIAMETER OF COUPLING SLEEVE

2.60 kg
WEIGHT WITHOUT PACKAGING (NET)

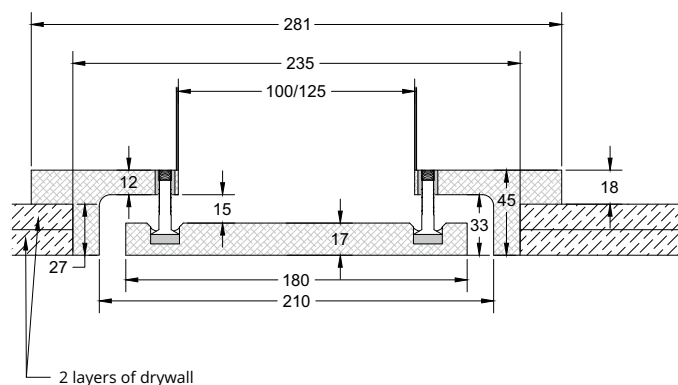
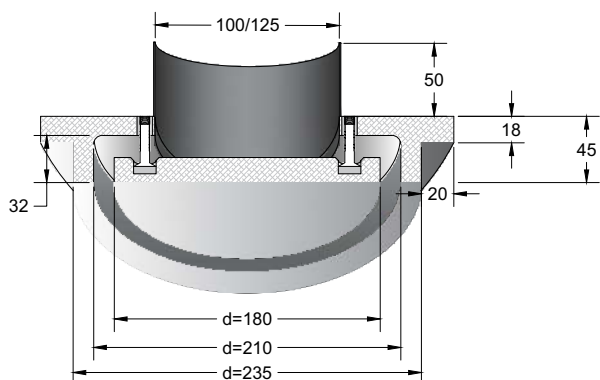

Airborne noise and resistance, 1 m.

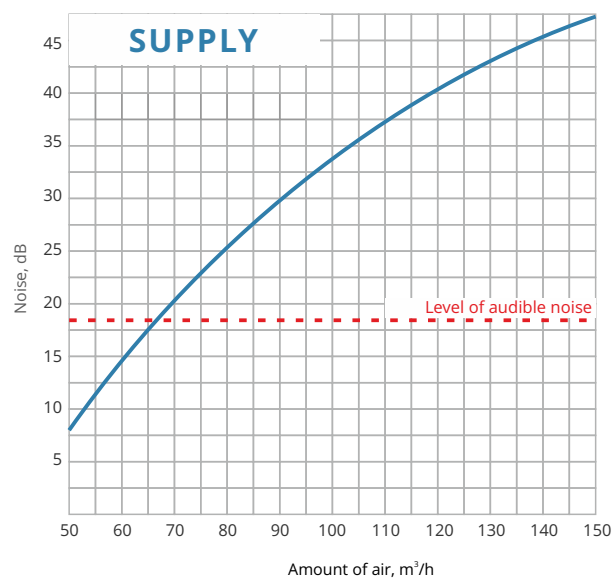
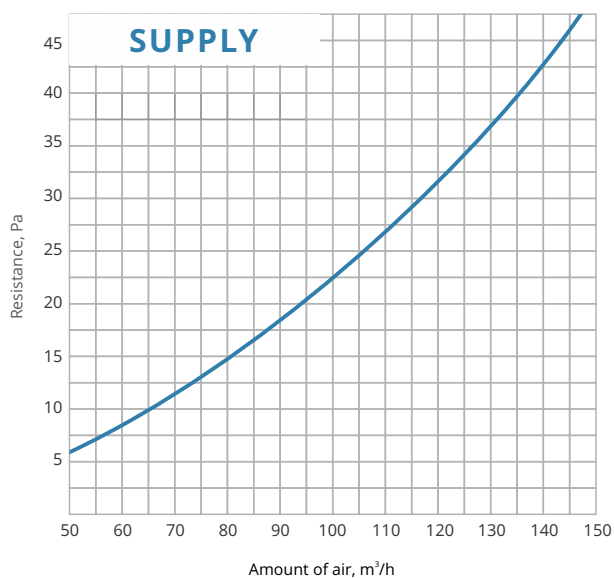

SENSIBLE AIRFLOW

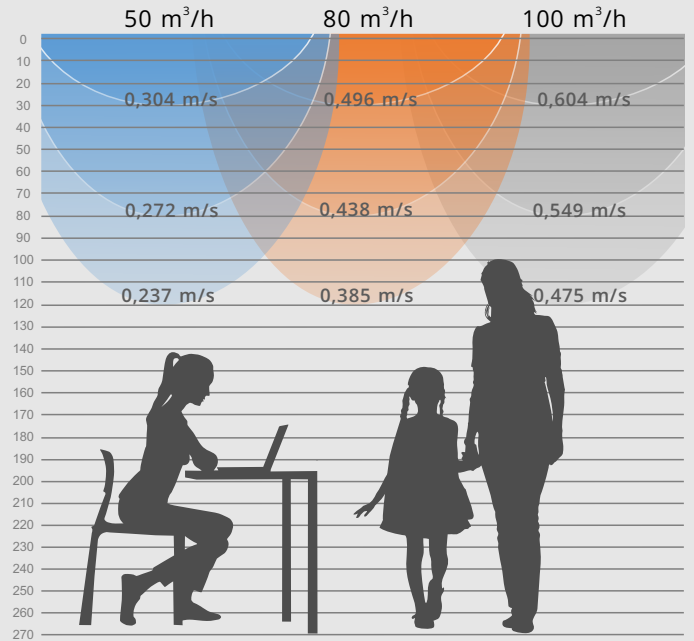

Airflow perceptible with the Circle diffuser at a height of 2.70 m

The round slot CIRCLE diffuser is ideally suited to a variety of room sizes. Can be used for both air supply and air extraction.

Air velocity at distance from diffuser

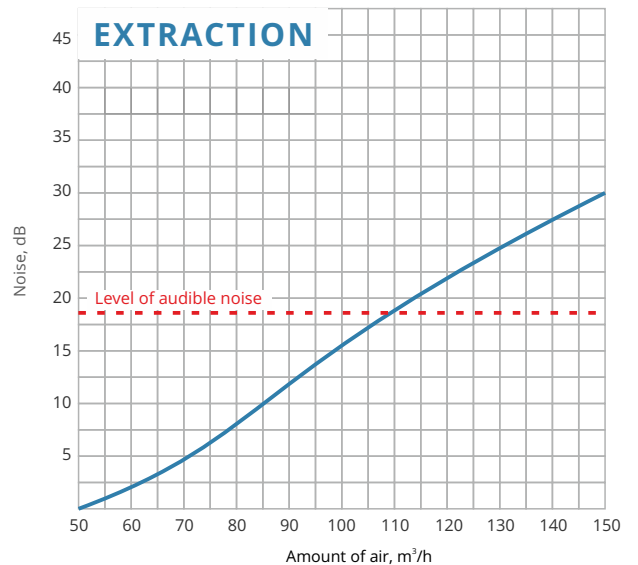
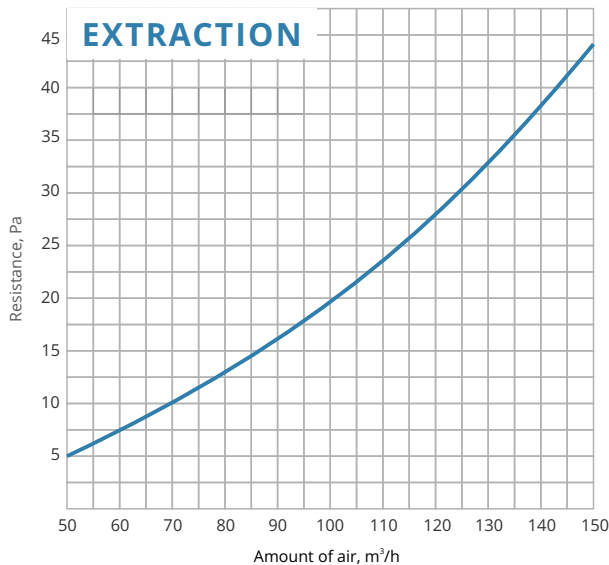
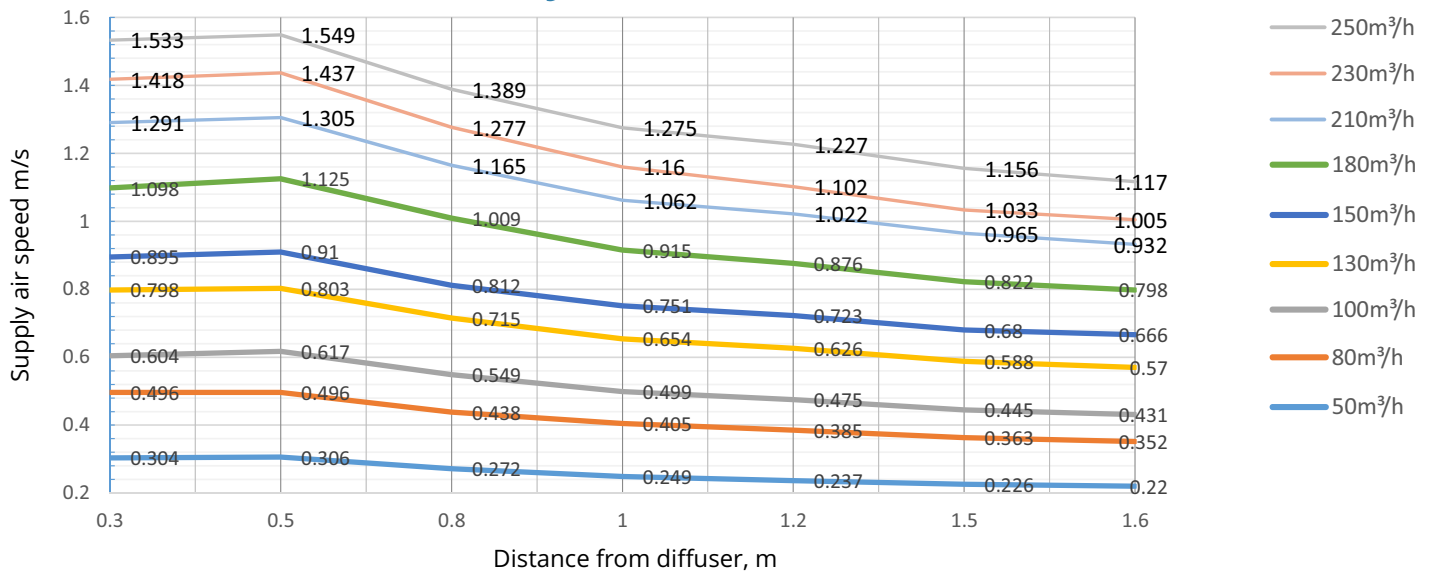

CIRCLE 160

ROUND DIFFUSER



160 mm
DIAMETER OF COUPLING SLEEVE

3.20 kg
WEIGHT WITHOUT PACKAGING (NET)

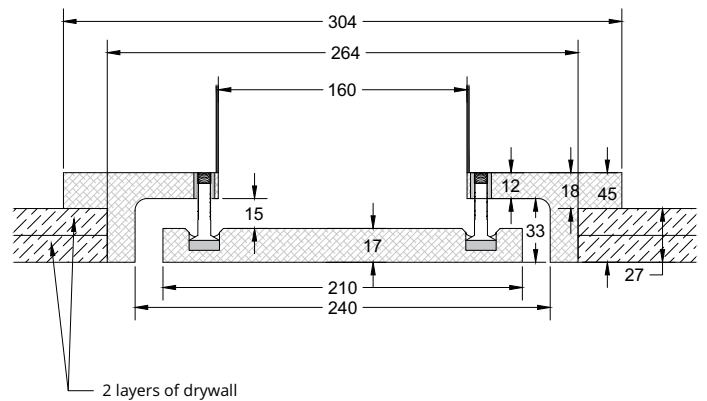
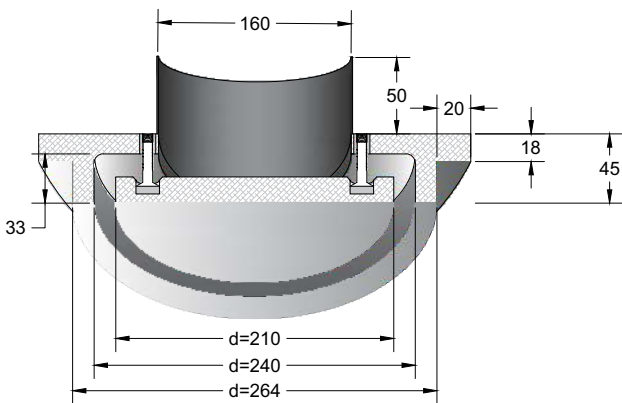

Airborne noise and resistance, 1 m.

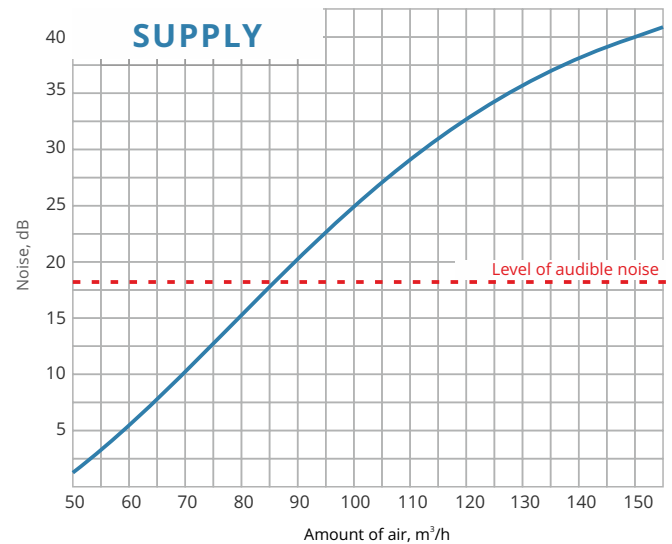
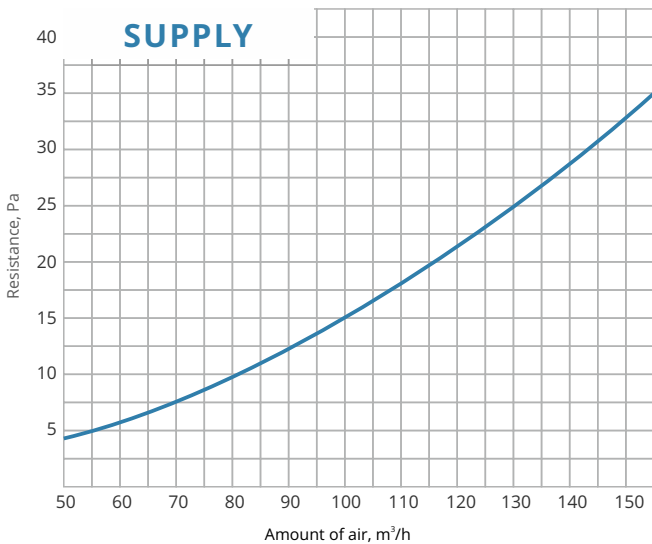

SENSIBLE AIRFLOW

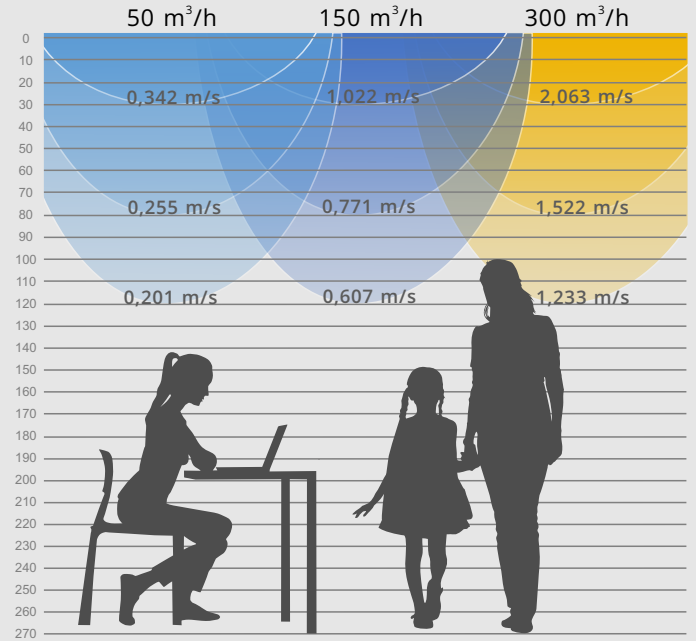

Airflow perceptible with the Circle diffuser at a height of 2.70 m

The round slot CIRCLE diffuser is ideally suited to a variety of room sizes. Can be used for both air supply and air extraction.

Air velocity at distance from diffuser

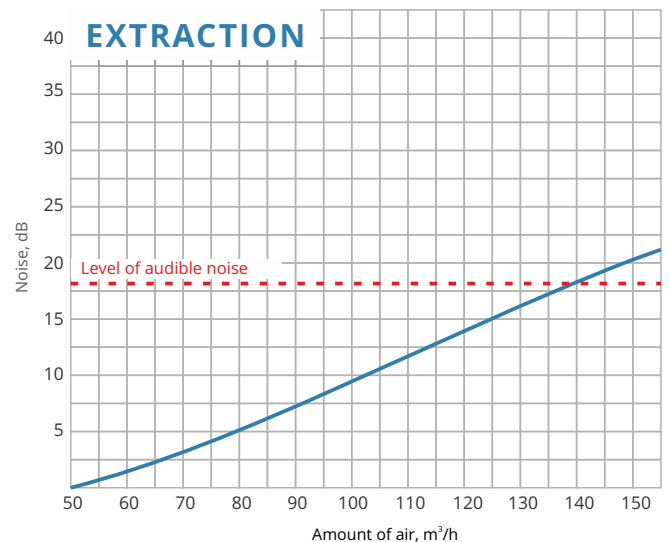
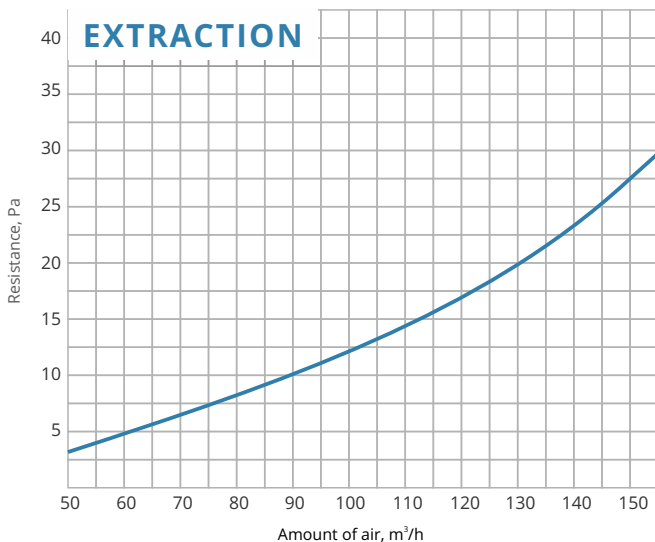
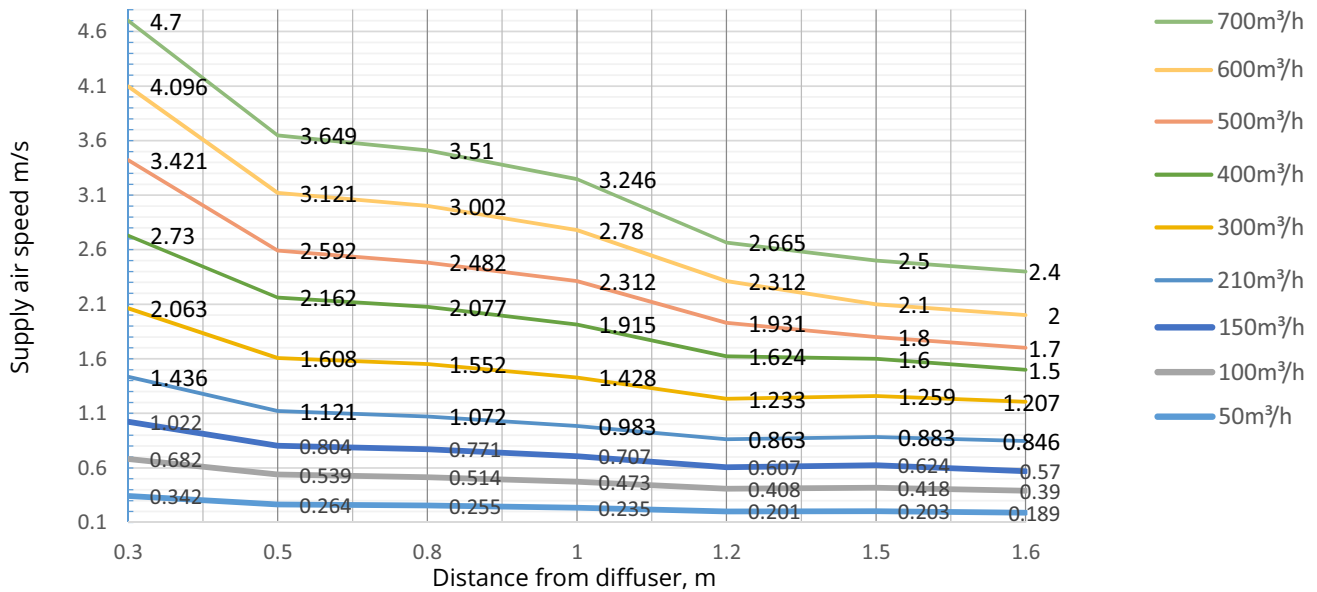

CIRCLE 200/250

ROUND DIFFUSER

200/250 mm
DIAMETER OF COUPLING SLEEVE

3.90 kg
WEIGHT WITHOUT PACKAGING (NET)

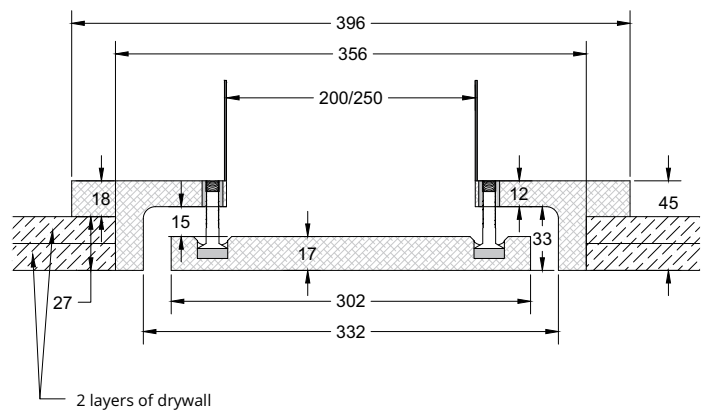
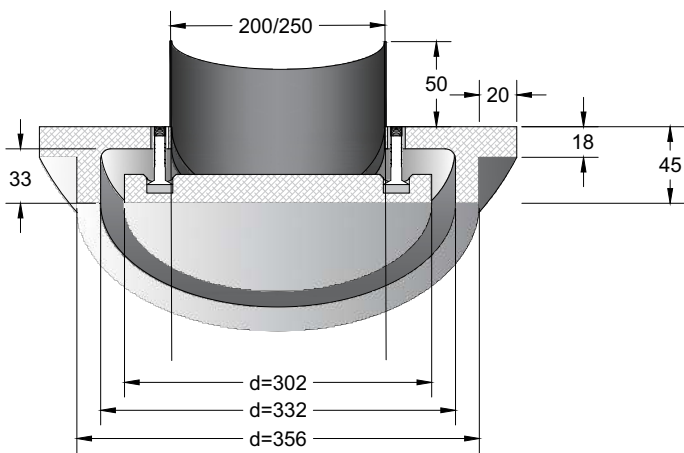

Airborne noise and resistance, 1 m.

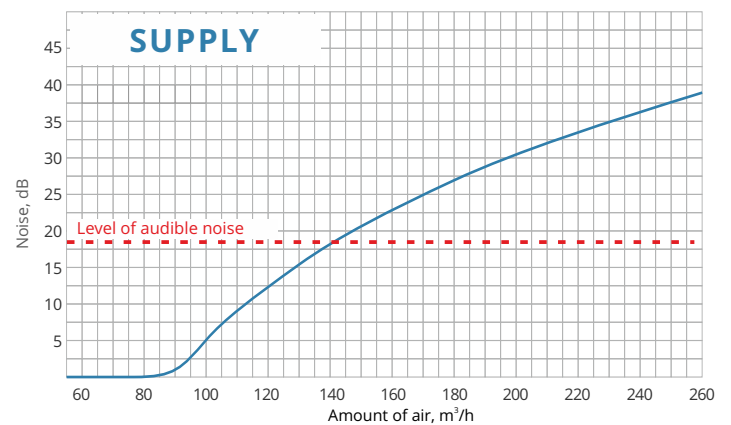
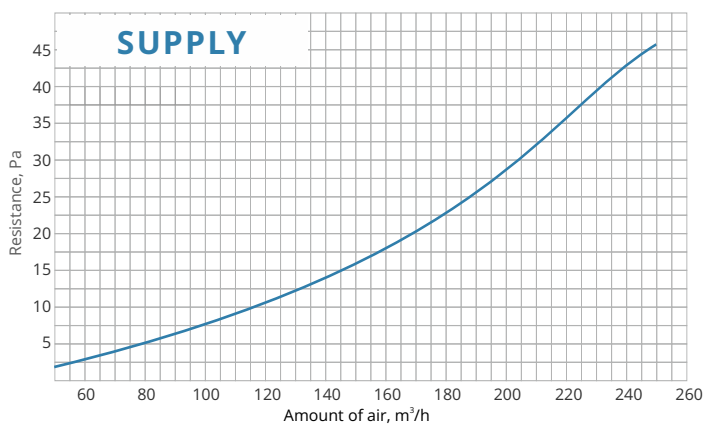

The round slot CIRCLE diffuser is ideally suited to a variety of room sizes. Can be used for both air supply and air extraction.

SENSIBLE AIRFLOW

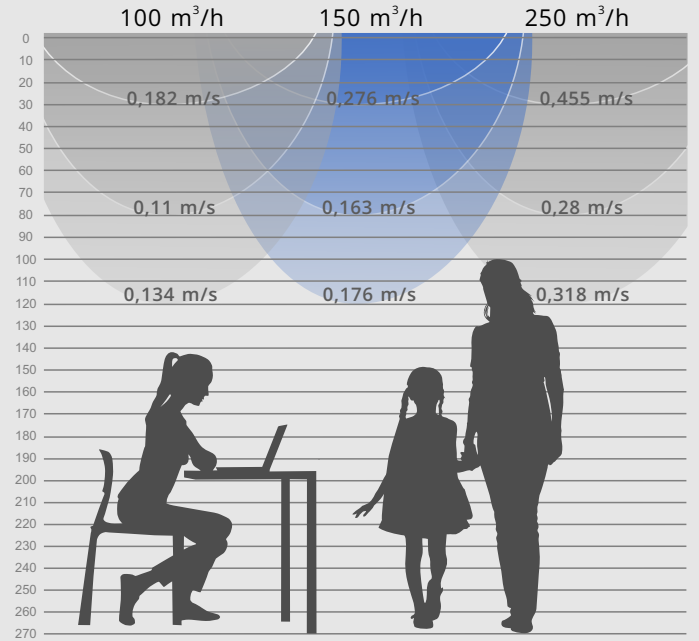

Airflow perceptible with the Circle diffuser at a height of 2.70 m

Air velocity at distance from diffuser

